



**Hand-Held Scarifiers**



**Needleguns**



**Walk-Behind Scarifiers**



**Impact Tools**



**Sanders**



**Specialty Tools**











**Industrial Vacuums**

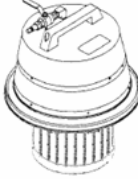
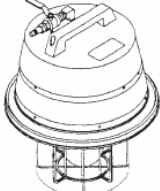

# 30 & 55 Gallon Vacuums

## Pneumatic w/Single Venturi

### Consumables

Item	Configurations	
	Critical Filtration 340.87530.01 (30 gal) 340.87555.01 (55 gal)	Wet/Dry 340.70530.01 (30 gal) 340.70555.01 (55 gal)
ULPA Filter	340.110029  Pictured w/ULPA filter on vacuum head	n/a  Pictured w/wet-dry float-ball shut off.
Pre-Filter Sleeve	340.110030PKG (6 pk) 	n/a
Cloth Bag	340.805058 (gray) 	340.805015 (white)  (Optional, dry only)
Paper Filter Protector	340.805038PKG (12 pk) 	340.805038PKG (12 pk)  (Optional, dry only)
Drum Liner	340.805037 (30 gal) 340.805046 (55 gal)  (Optional)	340.805037 (30 gal) 340.805046 (55 gal)  (Optional, dry only)
Collection Bag	n/a	n/a

### Accessories

Part	Description
300.082	Vacuum hose 1.5" x 10', replacement, complete
340.000001	Vacuum hose 1.5" x 25', replacement, complete
300.039	Vacuum hose 1.5" x 25', extension, coupler required
340.390014	Inlet coupler, 1.5", w/swivel cuff
300.066	Hose cuff, 1.5"
340.490024.1	Tool kit, plastic, 7 piece
340.490025.1	Tool kit, aluminum, 11 piece

### DESCO Mfg. Co., Inc.

23031 Arroyo Vista • Rancho Santa Margarita, CA 92688  
 949.858.7400 • 949.858.9141 fax • 800.337.2648 toll free  
 www.descomfg.com • info@descomfg.com





# Critical Filtration Vacuums

Consumable Life & Provisioning Guidelines

## Provisioning of Vacuum Consumables

Below are guidelines designed to give an idea of how many consumable items should be on hand to keep a vacuum system running efficiently. Actual consumable requirements vary widely due to the number of variables involved, including: tank size, debris volume, and particle size. As a result, there is no accurate way to predict consumable consumption. Therefore, the guidelines below should be used for initial provisioning. Once you have usage data, you can adjust to suit your actual needs.

### Recommended Initial Provisioning

Stage	Item	Vacuum Systems Provisioned								
		1 Vacuum			2 Vacuums			3 Vacuums		
		Qty Rec	Pkg Qty	Order Pkgs	Qty Rec	Pkg Qty	Order Pkgs	Qty Rec	Pkg Qty	Order Pkgs
1	Collection Bag	20	10	2	30	10	3	40	10	4
2	Paper Filter Protector	10	10	1	20	10	2	30	10	3
3	Cloth Bag	2	1	2	3	1	3	4	1	4
4	Pre-Filter Sleeve	2	6	1	3	6	1	4	6	1
5	ULPA Filter	1	1	1	2	1	2	3	1	3

## Critical Filtration and Vacuum Efficiency

- **Efficiency** is a balance of: 1) maintaining effective particle removal as measured by the ULPA specification while, 2) maintaining rated vacuum air flow as measured in cubic feet per minute (CFM).
- **Maintaining air flow** volume is critical to maintain the level of cleanliness required by the process.
- **Air flow declines** as particulate embeds in the filter fabric. As a result, efficiency decreases as filters use increases.
- **Efficiency is maintained** by checking and servicing filters often – before vacuum air flow declines significantly.
- **Multi-stage filtration is sacrificial.** Meaning each filtration stage sacrifices itself to save the next stage. Changing early filtration stages often (such as collection bag & filter protector) will greatly extend the life of the later filtration stages. **Key to understand** is that besides being an efficiency measure, this is also an **economy measure** as the early stages of filtration are far less expensive than the ULPA filter.

## Filtration Stages and Maintenance Steps

Maintenance Interval	Collection Bag	Filter Protector	Cloth Bag	Pre-Filter Sleeve	ULPA Filter
12.5	■				
25.0	■				
37.5	■	■			
50.0	■	■			
62.5	■	■			
75.0	■	■			
87.5	■	■			
100.0	■	■			
112.5	■	■			
125.0	■	■	■		
137.5	■	■			
150.0	■	■			
162.5	■	■			
175.0	■	■			
187.5	■	■			
200.0	■	■			
212.5	■	■			
225.0	■	■			
237.5	■	■			
250.0	■	■	■		
262.5	■	■			
275.0	■	■			
287.5	■	■			
300.0	■	■			
312.5	■	■			
325.0	■	■			
337.5	■	■			
350.0	■	■			
362.5	■	■			
375.0	■	■	■		
387.5	■	■			
400.0	■	■			
412.5	■	■			
425.0	■	■			
437.5	■	■			
450.0	■	■			
462.5	■	■			
475.0	■	■			
487.5	■	■			
500.0	■	■	■		
512.5	■	■			
525.0	■	■			
537.5	■	■			
550.0	■	■			
562.5	■	■			
575.0	■	■			
587.5	■	■			
600.0	■	■			
612.5	■	■			
625.0	■	■	■		
637.5	■	■			
650.0	■	■			
662.5	■	■			
675.0	■	■			
687.5	■	■			
700.0	■	■			
712.5	■	■			
725.0	■	■			
737.5	■	■			
750.0	■	■	■		
762.5	■	■			
775.0	■	■			
787.5	■	■			
800.0	■	■			
812.5	■	■			
825.0	■	■			
837.5	■	■			
850.0	■	■			
862.5	■	■			
875.0	■	■	■		
887.5	■	■			
900.0	■	■			
912.5	■	■			
925.0	■	■			
937.5	■	■			
950.0	■	■			
962.5	■	■			
975.0	■	■			
987.5	■	■			
1000.0	■	■	■	■	



- 1) **Collection Bag** – A disposable container where dust particles are accumulated for disposal.
  - *Particle containment efficiency:* 90% at 5 microns, *Typical Life:* Up to 12.5 hours
  - Check space available every 4 hours of operation. More often for heavy volume pickup.
  - Change when ¾ full. Change more frequently when collecting fine dust particles, such as concrete dust.
  - Always change. Never empty and reuse.
  - Always check stages 2-5 when changing collection bag.



- 2) **Paper Filter Protector** – A disposable filter designed to catch particles that pass through the collection bag (Stage 1) and to protect the cloth bag (Stage 3).
  - *Particle containment efficiency:* 97% at 5 microns, *Typical Life:* Up to 25 hours
  - Change when compromised: punctured, visibly contaminated or air flow is restricted.
  - If not visibly compromised, change with every second collection bag.
  - Always change. Never clean and reuse.
  - When replaced, stage 1 should also be replaced.



- 3) **Cloth Bag** – A reusable filter designed to catch particles that pass through the Paper Filter Protector (Stage 2) and to protect the Pre-Filter Sleeve (Stage 4).
  - *Particle containment efficiency:* 95% at 3 microns, *Typical Life:* Up to 125 hours
  - Always change when vacuum has been used with HAZMAT. Never clean and reuse.
  - Reusable only when you are certain the vacuum has not been used for HAZMAT. Clean by vacuuming exterior of the bag with a second vacuum.
  - Change when compromised: punctured, visibly contaminated or air flow is restricted.
  - When replaced, stages 1 and 2 should also be replaced.



- 4) **Pre-Filter Sleeve** – A reusable filter designed to catch particles that pass through the Cloth Bag (Stage 3) and to protect the ULPA filter (Stage 5).
  - *Particle containment efficiency:* 99% at 1-3 microns, *Typical Life:* Up to 250 hours
  - Always change when vacuum has been used with HAZMAT. Never clean and reuse.
  - Reusable only when you are certain the vacuum has not been used for HAZMAT. Clean by vacuuming exterior of the sleeve with a second vacuum.
  - Change when compromised: punctured, visibly contaminated or air flow is restricted.
  - When replaced, stages 1, 2 and 3 should also be replaced.



- 5) **ULPA Filter** – A disposable filter designed to catch particles that pass through the Pre-filter Sleeve (Stage 4).
  - *Particle containment efficiency:* 99.999% at 0.12 microns, *Typical Life:* Up to 1,000 hours
  - Change when compromised: punctured, visibly contaminated or air flow is restricted.
  - Always change. Never clean and reuse.
  - When replaced, stages 1, 2, 3 and 4 should also be replaced.

### DESCO Mfg. Co., Inc.

23031 Arroyo Vista • Rancho Santa Margarita, CA 92688  
 949.858.7400 • 949.858.9141 fax • 800.337.2648 toll free  
 www.descomfg.com • info@descomfg.com